

Specification Data

Panasonic Ventilation Fan



FV-11VH1 (110 CFM)

Description

Ventilating fan shall be Low Noise ceiling mount type rated for continuous run. Fan shall be ENERGY STAR rated and certified by the Home Ventilating Institute (HVI). Heating Elements shall be included. Evaluated by Underwriters Laboratories and conform to both UL and cUL safety standards. Fan is not intended for installation over a tub/shower enclosure.

Motor/Blower:

- Four-pole totally enclosed condenser motor rated for continuous run.
- Power Rating shall be 120 volts and 60 Hz.
- Motor equipped with thermal-cutoff fuse.
- Removable with permanently lubricated plug-in motor.

Housing:

- Rust proof paint, galvanized steel body.
- 4" diameter duct adapter.
- Built in backdraft damper.

Grille:

- Attractive design using steel with powder coat paint.
- Attaches directly to housing with torsion springs.

Heater:

- Tubular steel sheathed heating element. Nichrome wire with magnesium oxide for optimal heat transfer and electrical insulation at elevated temperatures.
- Adjustable directional louver.
- 70 CFM super quiet, energy efficient blower motor.

Warranty:

- The factory warranty shall be a minimum of 3 years limited warranty on parts.

Typical Specifications:

Ventilating Fan, Heater combination shall be of the ceiling mount, ENERGY STAR rated type, with no less than 110 CFM and no more than 1.1 sone as certified by the Home Ventilating Institute (HVI) at 0.1 static pressure in inches water gauge. Ventilating fan power consumption shall be no greater than 25 watts and ENERGY STAR rated with efficiency rating of no less than 4.5 CFM/watt. The motor shall be totally enclosed, four pole condenser type engineered to run continuously. Power rating shall be 120v/60Hz. Duct diameter shall be no less than 4". Fan shall be California Title-24 compliant.

Heating element shall be Nichrome wire in tubular steel sheath construction with magnesium oxide for optimal heat transfer. Heating element power consumption no less than 1400 watts. Heating feature shall include a 70 CFM blower fan with energy efficient condenser type motor. Heating feature shall include an adjustable directional louver.

The heating element is designed to be used for supplemental heating only and does not contribute to the ENERGY STAR qualification of the product.

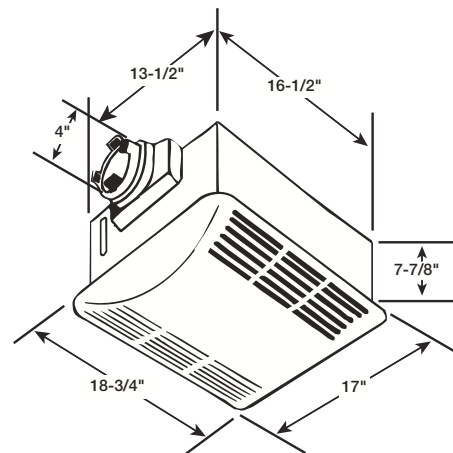

Fan Curve FV-11VH1

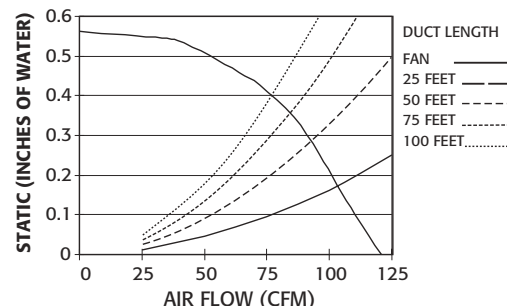

Specifications:		
	FV-11VH1	
Static pressure in inches w.g.	0.1"	0.25"
Air Volume (CFM)	110	98
Noise (sones)	1.1	NA
Power Consumption (Watts)	25	24
Energy Efficiency: CFM/Watt	4.5	4.1
Speed (RPM)	1036	1207
Heating Element (Watts)	1400	
Heater Fan (Watts)	24	
Fan/Heater/Light/Night-Light (Watts)	1475	
Fan/Heater/Light/Night-Light (Amps)	12.1	
ENERGY STAR Rated	Yes	
Washington State VIAQ Code	Yes	

As of 11/06

For Complete Installation Instructions Visit www.panasonic.com/building



Model	Quantity	Comments	Project:
			Location:
			Architect:
			Engineer:
			Contractor:
			Submitted by:
			Date: